



Shure Brothers Incorporated
 222 Hartrey Avenue
 Evanston IL 60202-3696 U.S.A.

Model SM7 User Guide

MODEL SM7 UNIDIRECTIONAL DYNAMIC RECORDING MICROPHONE

The Model SM7 is a dynamic microphone with a very smooth, flat, wide-range frequency response. It is meticulously designed for the most exacting music and speech requirements in professional audio applications.

Microphone Features:

- Flat, wide-range frequency response for exceptionally clean and natural reproduction of both music and speech
- Classic cardioid polar pattern, uniform with frequency and symmetrical about axis, to provide maximum rejection and minimum coloration of off-axis sound
- Internal "air suspension" shock isolation virtually eliminates mechanical noise transmission
- Highly effective pop filter eliminates need for any add-on protection against explosive breath sounds, even for close-up vocals or narration
- Extremely good rejection of electromagnetic hum due to built-in hum rejection system
- Bass rolloff and mid-range emphasis (presence boost) controls with graphic display of response setting. (See Figure 1)
- Yoke mounting with captive stand nut for easy mounting and dismounting provides precise control of microphone position
- Rugged construction and excellent cartridge protection for outstanding reliability

APPLICATIONS

The Model SM7 was field-designed in major recording studios and scoring stages to be the finest dynamic microphone available for music recording and reproduction. Exacting laboratory development programs augmented the field-derived specifications and features to extend the advantages of the SM7 to a wide variety of critical professional audio applications.

The exceptional performance and unique features of the SM7 make it the outstanding choice for such applications as:

- Recording Studio — Instrumental and Vocal
- Location Recording
- Motion Picture and Television Scoring
- Television Talk Shows and News Desks
- Radio Announcing and Production
- Narration
- Fishpole

SPECIFICATIONS

Type

Dynamic

Frequency Response

40 to 16,000 Hz (see Figure 1)

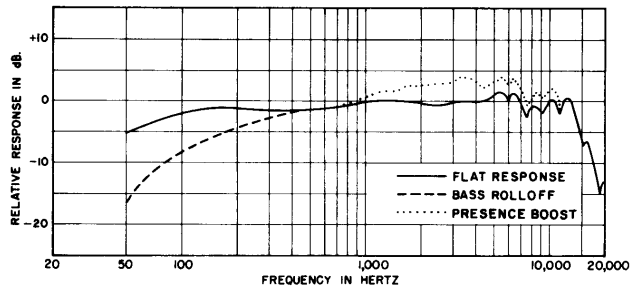

TYPICAL FREQUENCY RESPONSE
 FIGURE 1

Polar Pattern

Cardioid (unidirectional)—uniform with frequency, symmetrical about axis (see Figure 2)

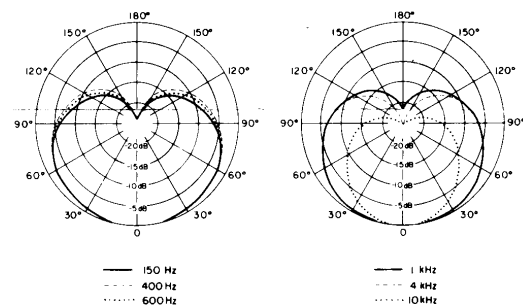

TYPICAL POLAR PATTERNS
 FIGURE 2

Impedance

Microphone rating impedance is 150 Ω (150 Ω actual) for connection to microphone inputs rated at 19 to 300 ohms.

Output Level (at 1,000 Hz)

Open Circuit Voltage* - 79.0 dB (.11 mV)

*0 dB = 1 volt per μbar

PowerLevel** -57.0 dB

**0 dB = 1 milliwatt per 10 μbars

Hum Sensitivity (maximum)

13 dB equivalent SPL/millioersted
(1 mV/10 oersted)

Switches

Bass Rolloff and Mid-Range Emphasis: Slotted response selector switches. See Figure 1 for bass rolloff and mid-range emphasis (presence boost) response. See Figure 3 for location of switches.

Response Selector Switch Cover

Cover plate (supplied) can be used to prevent accidental change of response setting.

Cartridge Shock Mount

Internal air-suspension shock- and vibration- isolator

Microphone Connector

Three-pin professional audio connector designed to mate with Cannon XL series, Switchcraft A3 (Q-G) series or equivalent connector.

Swivel Assembly

Integral part of microphone with captive nut for ease of attachment to stand, suitable for mounting on stand with 5/8 in-27 thread.

Case

Dark gray enamel aluminum and steel case with dark gray foam windscreen

Dimensions

See Figure 3

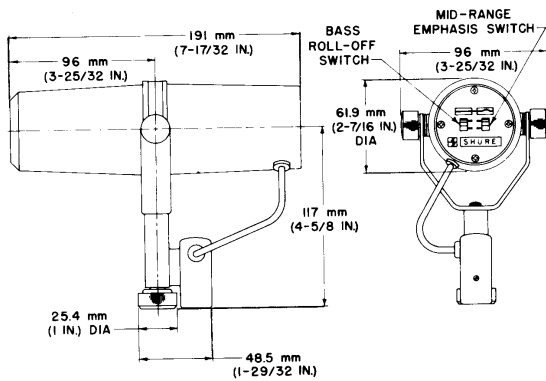

OVERALL DIMENSIONS
FIGURE 3

Net Weight

764 grams (1 lb, 11 oz)

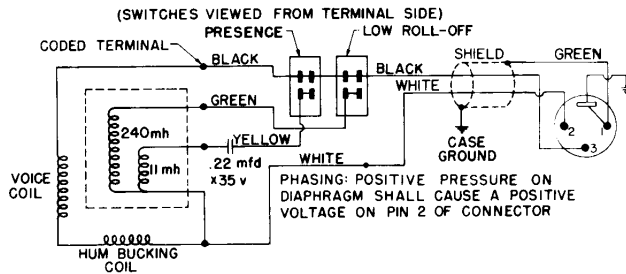

INTERNAL CONNECTIONS
FIGURE 4

FURNISHED ACCESSORY

Switch Cover Plate 53A1884

OPTIONAL ACCESSORIES

DeskStand S37A, S39A
Cable and Plug Assembly (7.6m – 25 ft) C20F

For additional service or parts information, please contact Shure's Service department at 1-800-516-2525. Outside the United States, please contact your authorized Shure Service Center.

ARCHITECTS' SPECIFICATIONS

The microphone shall be a moving coil (dynamic) type with a frequency response of 40 to 16,000 Hz. The unit shall have a cardioid polar characteristic. The cancellation at the sides shall be approximately 6 dB and the cancellation at the rear shall be 15 to 20 dB. The microphone shall be low impedance with a rated impedance of 150 ohms for connection to microphone inputs rated at 19 to 300 ohms. The microphone output shall be -57.0 dB where 0 dB = 1 milliwatt per 10 microbars.

The microphone shall have two switches for controlling the frequency response. The first switch is a Bass Rolloff selector switch. One position of this switch provides a flat low frequency response and the second position provides a gradual-low frequency rolloff. The second switch is the Mid-Range Emphasis (presence boost) switch. One position of this switch provides a flat mid-range frequency response and the second position raises the level of the mid-range frequency response. The microphone shall be equipped with an integral swivel assembly suitable for mounting on a stand with a 5/8 in-27 thread.

The overall dimensions shall be 191 mm (7-17/32 in.) in length, 148 mm (5-13/16 in.) in height, and 96 mm (3-25/32 in.) in width.

The microphone shall be the Shure Model SM7 or equivalent.



The Sound of Professionals...Worldwide™

Shure Brothers Incorporated
222 Hartrey Avenue, Evanston IL 60202-3696