

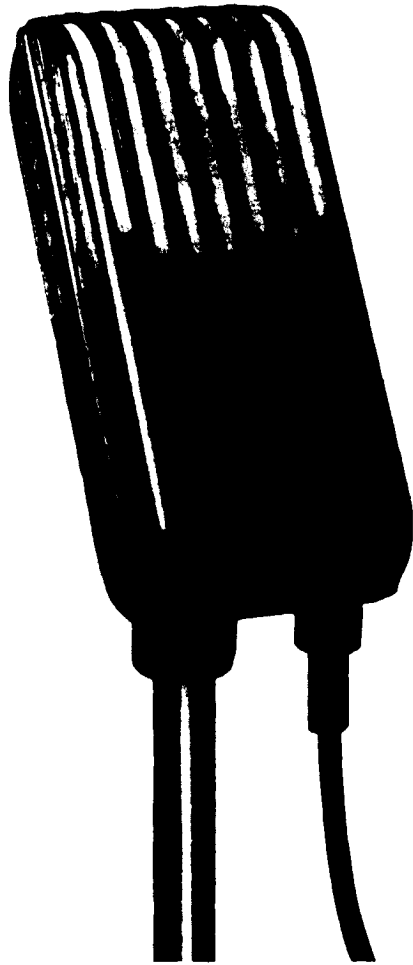

INSTRUCTIONS



Varacoustic Microphone

MI-6203-D

76332

Figure 1 — Microphone MI-6203-D

MI-6203-D

The Varacoustic Microphone may be used in public address systems, amateur radio stations, sound reinforcing systems, and other sound reproducing systems where a microphone with variable directional characteristics is desirable.

To obtain maximum performance, read these instructions carefully before placing the microphone in service.

TECHNICAL DATA

Effective Output Level

Unidirectional Position

- a. -58 dbm*
- b. 1.30×10^{-3} volts* (250-ohm output connection)
- c. RETMA sensitivity -150 db

Velocity Position

- a. -55 dbm*
- b. 1.83×10^{-3} volts* (250-ohm output connections)
- c. RETMA sensitivity -147 db

Pressure Position

- a. -61 dbm*
- b. 0.9×10^{-3} volts* (250-ohm output connection)
- c. RETMA sensitivity -153 db

Output Impedance

30, 150 and 250 ohms

Frequency Range

60 to 10,000 cycles See figure 2.

Mounting

5/8-inch 27 fixture thread

Directional Characteristics

May be varied See figure 3.

Cable

25-foot two-conductor shielded without plug.

Dimensions and Weight

Length - 6-7/8 inches
 Width - 2-3/4 inches
 Depth - 2-5/8 inches
 Weight - 3-1/2 pounds

*Sound Pressure = 10 dynes per square centimeter.

DESCRIPTION

The MI-6203-D Varacoustic Microphone is a high-fidelity ribbon type instrument which is designed to provide a variety of directional response patterns. The Varacoustic Microphone is especially recommended for public address, industrial sound and stage pick-up. It is intended primarily for indoor use and if used outdoors should be protected by a silk bag or other suitable windscreen. The choice of directional patterns makes it possible to regulate the field of pickup to a considerable extent with a resulting increase in signal-to-noise ratio. Reverberations and unwanted sounds such as audience noise, may also be reduced by proper adjustment and placement of the microphone.

INSTALLATION

Connections

The microphone is connected at the factory for an output impedance of 250 ohms and may be connected for 30 or 150 ohms by changing the transformer connections. To change the output impedance, remove the three screws at the back of the microphone (two near the sides and one at the bottom) and lift off the front half of the case. The terminal board will then be accessible and connections may be unsoldered and changed as shown in the

table in figure 4 to obtain the desired output impedance. The unused lead should be taped to prevent a short circuit.

IMPORTANT: When the microphone case is opened, care should be taken at all times to prevent entry of dirt or other foreign particles. A clean sheet of paper should be placed on the working surface and the soldering iron must be free from loose scale.

Recommended Load Impedance

It is recommended that the microphone be worked into an unloaded input transformer.

Directional Characteristics

The desired directional response is selected by moving the adjustable slider on the back of the microphone case to any of the marked positions. The positions lettered P, U and V refer to pressure, unidirectional and velocity operation respectively; the two intermediate positions are numbered 1 and 2. The directional characteristics are continuously variable and the slider may be stopped between any of the marked positions. Adjustment of the microphone will be determined by its location and the purpose for which it is used. The response for each position of the slide is shown in figure 3 and these diagrams

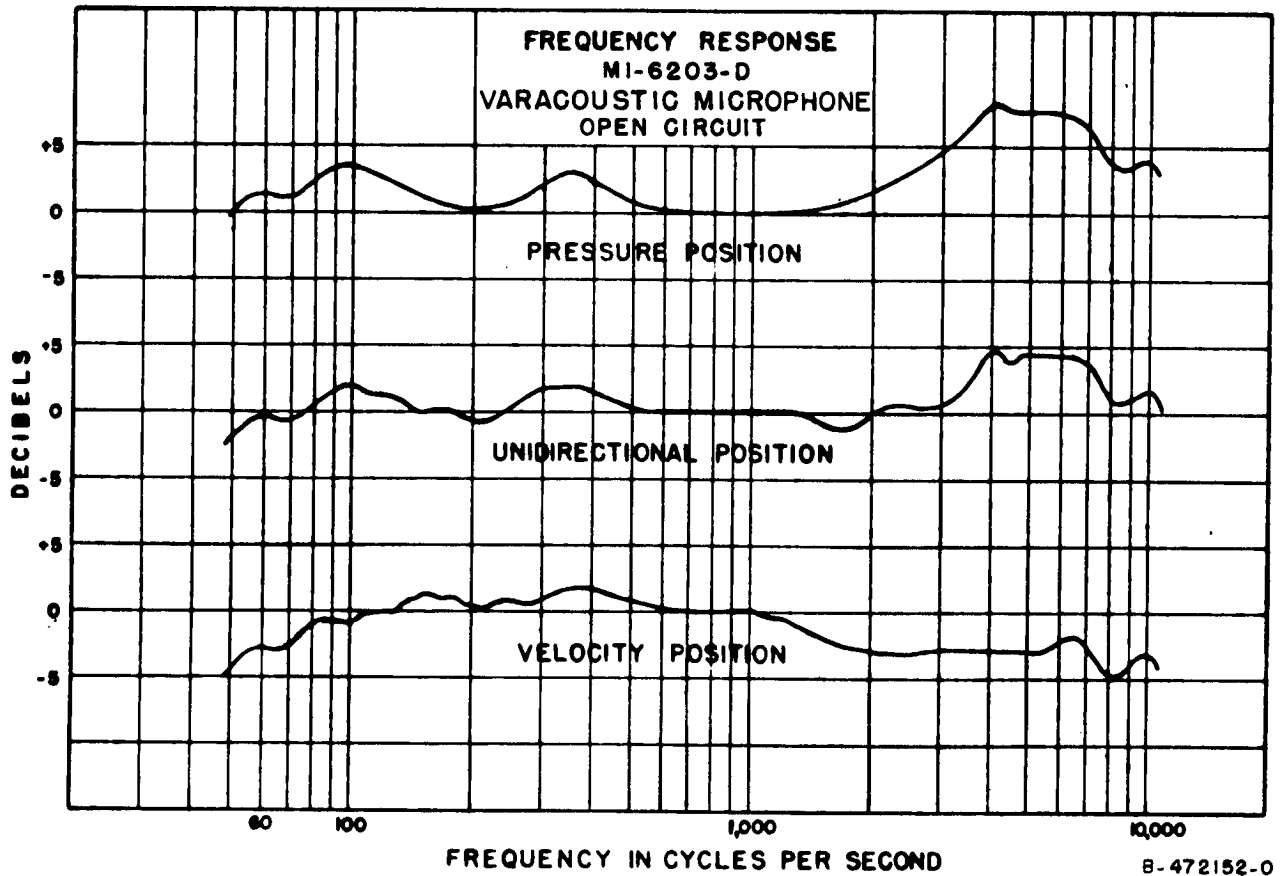

Figure 2 - Frequency Response

should be used as reference when selecting the directional response setting.

Phasing

When the outputs of two or more microphones are connected into a common mixing circuit it is necessary that their respective outputs be in phase. Otherwise the output of one will oppose the output of the other resulting in a reduction in output and introducing varying degrees of distortion.

To check the phasing of two or more microphones, connect one microphone to the amplifier input and set the volume control to obtain the desired output while talking into the microphone. Then connect the second microphone in parallel with the first and without changing the volume control setting, hold both microphones together and talk into them. If the resulting volume is less than the previous level, reverse the connections of one of the microphone cables at the amplifier input terminals. Check each additional microphone in the same manner changing the

cable connections if necessary to correct it to agree in phasing with those already connected.

If the sound source is behind the microphone, a large phase shift will occur when the slider is changed from the pressure to the velocity position or the reverse. To avoid undesirable effects from this cause, microphones, when operating close together, should all face the sound source and preferably be used with the same directional setting. Avoid having one microphone on the velocity setting and another on the pressure setting.

Stand Fitting

The Varacoustic Microphone is equipped with a 5/8 inch -27 fitting and may be mounted directly on stands such as the MI-4068-D. It may also be mounted on any stand designed for a 1/2-inch straight pipe fitting by using an adapter.

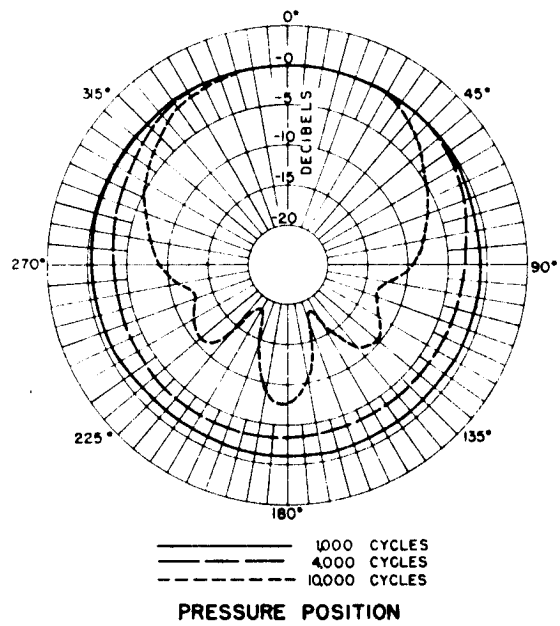
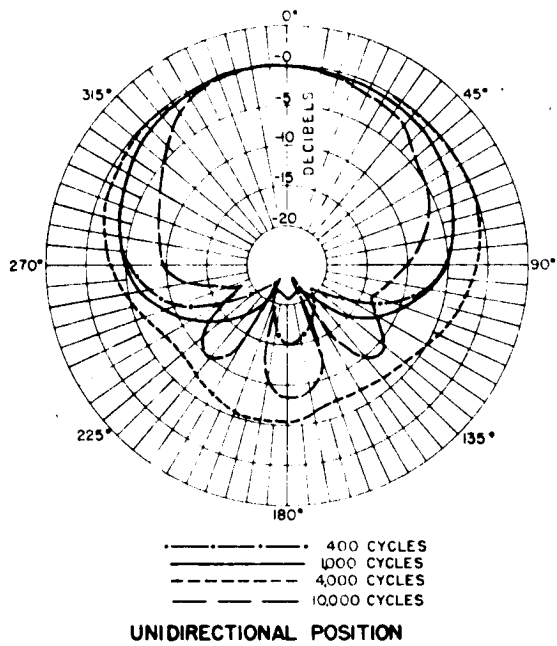
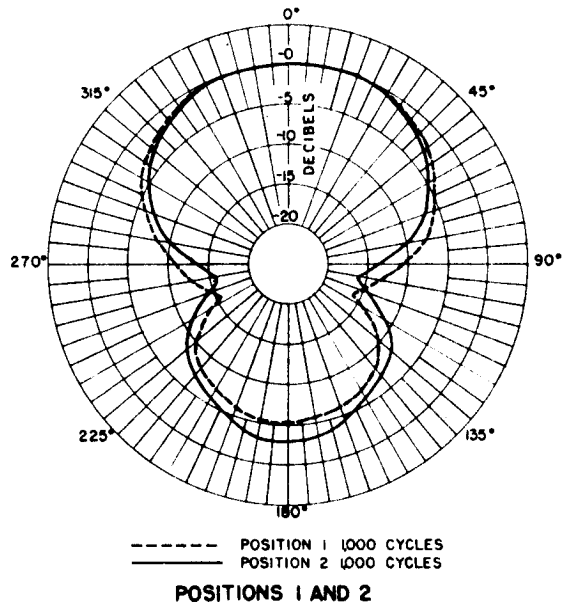
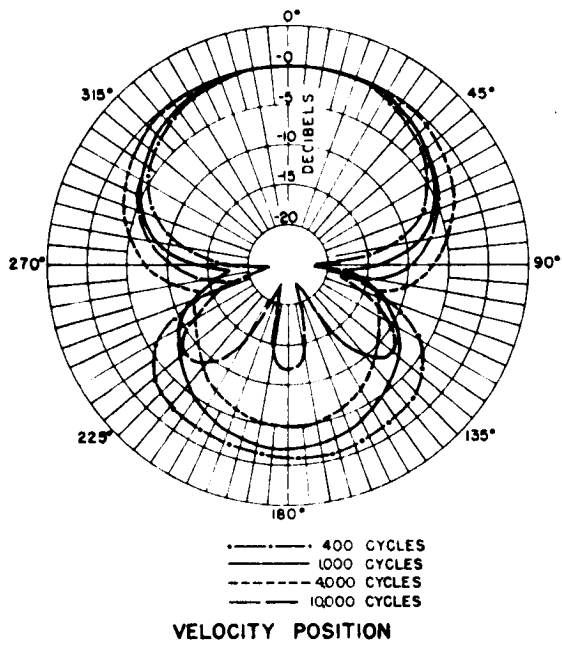

T-463372

Figure 3 - Directional Characteristics

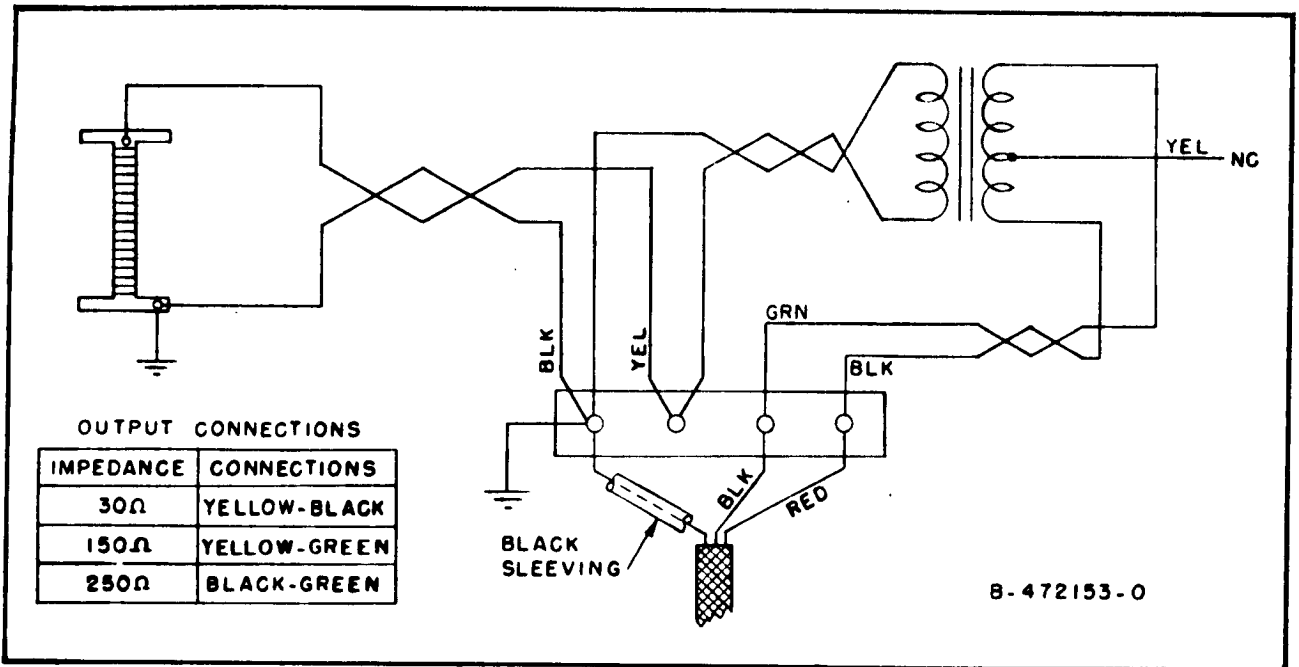

Figure 4 - Connection Diagram

Placement

Microphone placement is determined almost entirely by the individual requirements of each installation and it is impractical to give specific rules in this respect. The best results will be obtained as a result of experimental placement and monitoring but in general the following may be of assistance:

1. When used in velocity position, performers should not be closer to the microphone than approximately one foot. A distance of three feet or more is usually preferable since a shorter distance will result in an exaggerated low-frequency response.

2. Place the microphone so that its field of pickup will cover the sources of desired sound with unwanted sounds in the direction of minimum response. The directional response characteristics diagrams, figure 3, may be used as a guide.

3. Protect the microphone from strong winds and loud, explosive sounds as they may stretch the ribbon and cause permanent damage.

MAINTENANCE

It is not recommended that the customer attempt repairs other than replacement of transformers, mounting parts and cables. For microphone mechanism repairs, return the unit

to the factory. Secure a Repair Order and Returned Apparatus Tag from your RCA dealer. Attach the tag properly filled out to the damaged equipment, enclose the repair order in the package, and mail to RCA, Camden, New Jersey.

CAUTION: To prevent permanent damage to the ribbon, do not check connections to the transformer with a battery powered continuity meter.

To replace a cable or transformer, open the microphone case as directed under *Connections* and note the color coding of the leads. Unsolder the connections and replace the transformer or cable in the same manner as the one which was removed. Resolder the connections as previously noted using rosin-core solder.

Replacement Parts

The following parts list is included to provide identification when ordering replacement parts. Order from *RCA Replacement Parts Department, Camden, New Jersey*, giving the *Stock Number* and *Description* of the parts wanted. Replacement parts supplied may be slightly different in size or form from the original parts but will be completely interchangeable with them.

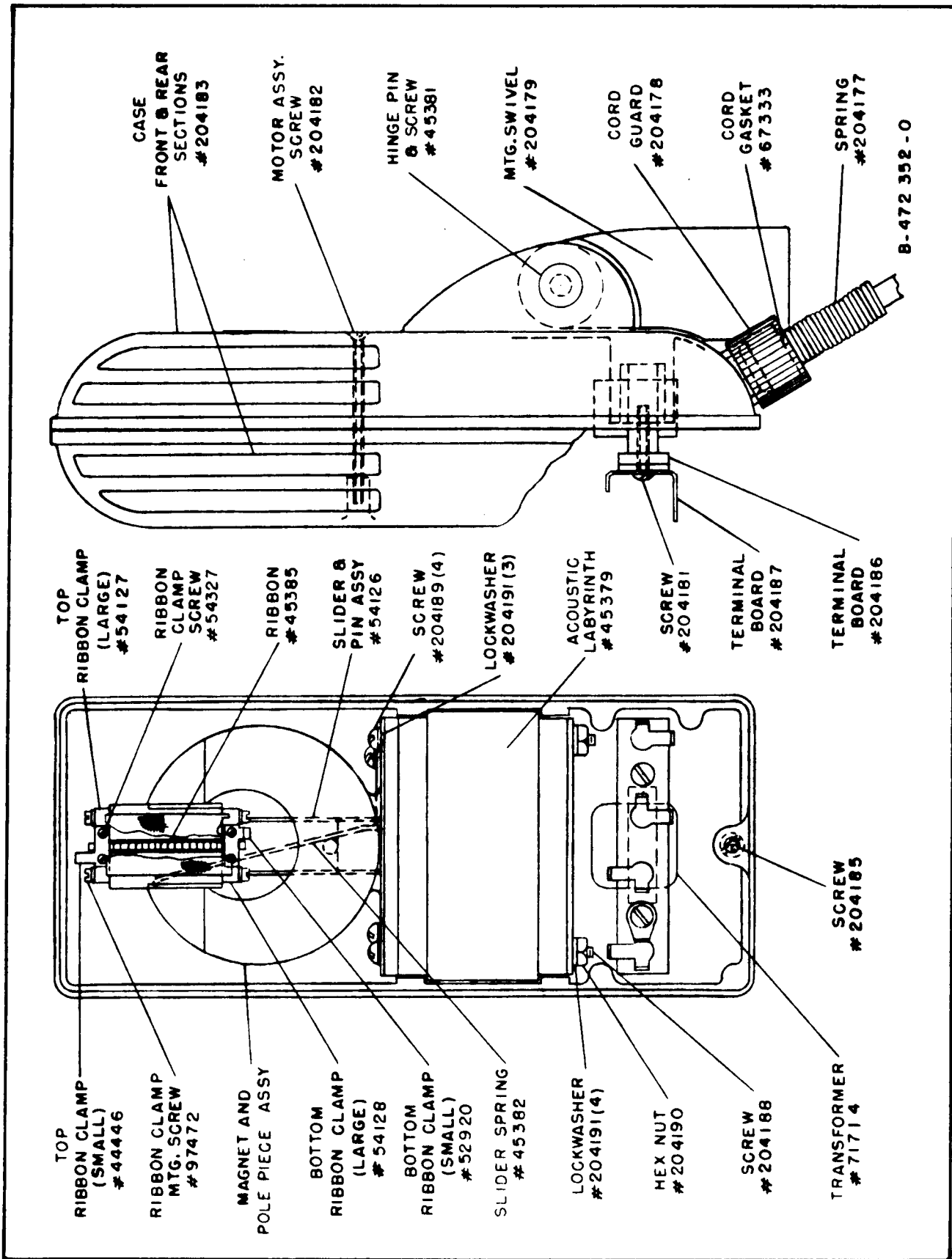

Figure 5 - Parts Location Diagram

LIST OF PARTS

Description	Stock No.
Board, terminal board insulator	204186
Board, terminal board assembly	204187
Case, front and rear sections (matched)	204183
Clamp, top ribbon clamp, small	44446 ✓
Clamp, top ribbon clamp, large	54127 ✓
Clamp, bottom ribbon clamp, small	52920 ✓
Clamp, bottom ribbon clamp, large	54128 ✓
Gasket, cord	67333
Labyrinth, acoustic	45379
Nut, cord guard	204178 ✓
Nut, for labyrinth assembly bolt hex nut #4-40	204190 ✓
Pin, hinge pin and screw	45381
Plate, escutcheon plate for slider and pin	204180
Ribbon, microphone	45385 ✓
Screw, bottom case screw, fil. hd. #4-40 x 3/16" lg.	204185

Description	Stock No.
Screw, labyrinth assembly bolt, fil. hd. #4-40 x 1-7/8" lg.	204188
Screw, motor assembly screw, fil. hd. #4-40 x 1-1/2" lg.	204182
Screw, mounting screw for magnet and pole piece to labyrinth rd. hd. #4-40 x 3/16" lg.	204189
Screw, ribbon clamp screw, fil. hd. #0-80 x 1/8" lg.	54327 ✓
Screw, terminal board screw, rd. hd. #4-40 x 3/4" lg.	204181
Screw, top and bottom ribbon clamp mounting screws fil. hd. #1-72 x 5/16" lg.	97472 ✓
Slider, acoustic tube slider and pin assembly	54126
Spring, cord guard	204177
Spring, slider	45382
Swivel, mic. mounting	204179
Transformer, microphone	71714
Washer, for labyrinth assembly, bolt lock washer #4	204191