



**Electro-Voice® RE18 and DO56  
Shock-Mounted  
Microphones**





## RE18

### Shock-Mounted Variable-D® Dynamic Cardioid

The RE18 is a direct descendant of the popular RE15 and RE16 microphones. While maintaining the accurate frequency response and super-cardioid polar pattern of the RE15, the RE18 has added an integral shock mount for even better performance. Superb shock isolation sharply reduces handling and cord noise, and in sound reinforcement systems it effectively silences mechanical stand and lectern noises. A refined, low-profile blast filter makes possible close hand-held use without "P-pops." The Memraflex grille screen resists dents and keeps its shape. A "hum-buck" coil rejects hum in the presence of heavy alternating magnetic fields from stage lighting and power transformers. The silver tone beige finish is perfect for TV.

Unlike "multi-port" directional microphones, E-V's exclusive Variable-D design insures uniform frequency response at all angles for uncolored off-axis pickup. Additionally, Variable-D design eliminates bass-boosting proximity effect for those situations where frequency response needs to be uniform regardless of the mike-to-sound-source working distance.

The super-cardioid polar response of the RE18 rejects more random unwanted noise than the standard cardioid pattern. Two nulls at 150° off axis instead of one at 180° off axis, make the RE18 superb for applications where ambient noise rejection is mandatory.



## DO56

### Shock-Mounted Dynamic Omnidirectional

The DO56 is a shock-mounted omnidirectional microphone for hand-held broadcast and sound reinforcement applications. All handling noises and cord vibration are isolated from the microphone element. Shock isolation is enhanced by having the main acoustic cavity and the diaphragm/voice-coil assembly isolated as a unit from the case. Butyl rubber shock rings act as the spring in the isolation system. A capsule/case collision is impossible. This "G-factor" margin makes the DO56 less susceptible to the bell-like clang heard from other shock-mounted microphones when they are accelerated or decelerated rapidly.

Frequency response extends to 18,000 Hz. A slow rolloff below 200 Hz (-8 dB at 50 Hz,) combined with slight emphasis in the 2,000-12,000 Hz range gives the DO56 excellent vocal qualities without low-frequency noise interference. A high-density Acoustifoam™ blast filter protects against "P-pops." The steel and aluminum case was chosen for perfect hand-held balance. The Memraflex grille screen bounces back to keep its shape. A slim, attractive silhouette and the silver tone beige finish are ideal for on-camera use.



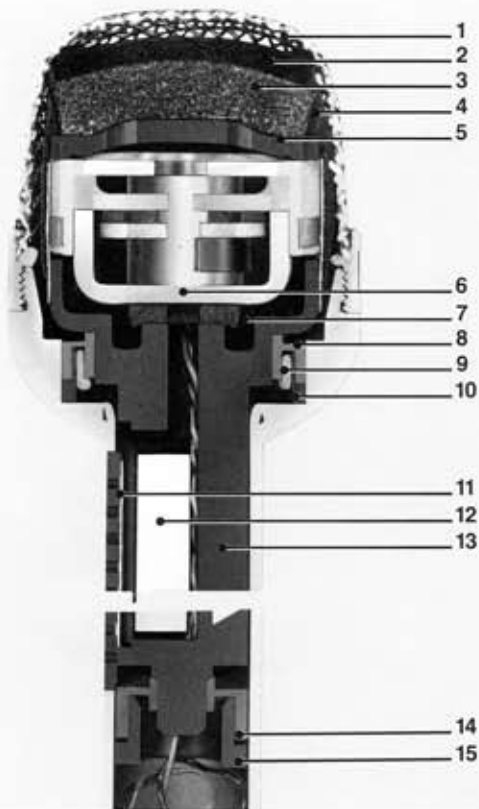

**Frequency Response:** 80-15,000 Hz

**Impedance:** 150 ohms

**Output:** - 57 dB

**Diaphragm:** EV Acoustalloy®

**Case:** Steel

**Finish:** Silver tone beige

**Size:**

178mm (7") long;

41mm (1<sup>25</sup>/<sub>32</sub>") max. diameter;

19mm (3/4") shank diameter

**Weight:** 230 grams (8 oz)

**Cable:** 4.6m (15') Switchcraft A3F conn.

**Included:** 312B stand adapter, protective vinyl carrying pouch

- 1 Memraflex grille screen
- 2 High-density Acoustifoam™ windscreen
- 3 Low-density Acoustifoam™ windscreen
- 4 Cloth side port windscreen
- 5 High-frequency-extending Helmholtz resonator
- 6 High-flux magnet structure
- 7 Fully isolated rear cavity
- 8 Butyl rubber front shock mount
- 9 Silicon oil-filled impact damping pad
- 10 Nonmetallic mount support
- 11 Variable-D port grille screen
- 12 Resonance-lowering lead counterweight
- 13 Nonmetallic transducer body
- 14 Butyl rubber rear shock mount
- 15 Nonmetallic mount support

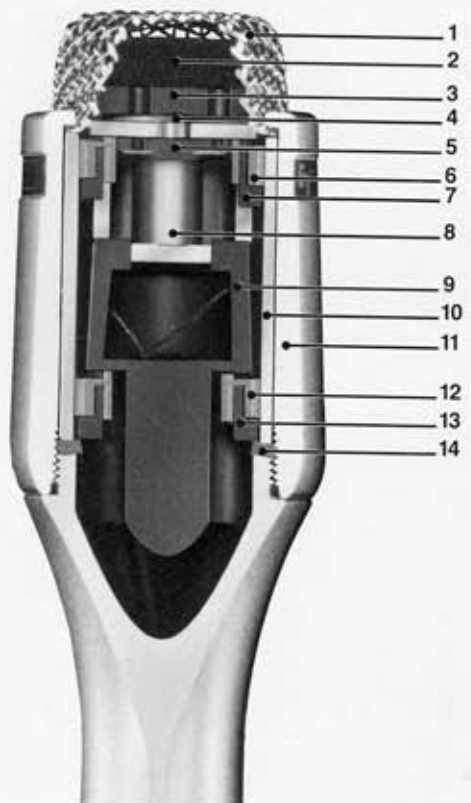
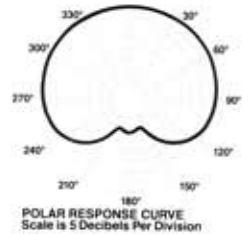
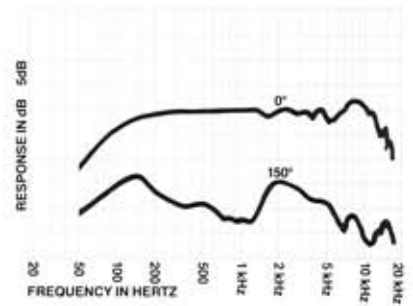

**Frequency Response:** 80-18,000 Hz

**Impedance:** 150 ohms

**Output:** - 61 dB

**Diaphragm:** EV Acoustalloy®

**Case:** Steel and aluminum

**Finish:** Silver tone beige

**Size:**

159mm (6<sup>1</sup>/<sub>4</sub>") long;

37mm (1<sup>15</sup>/<sub>32</sub>") max. diameter;

19mm (3/4") shank diameter

**Weight:** 185 grams (6.5 oz)

**Cable:** 4.6m (15') Switchcraft A3F conn.

**Included:** 312B stand adapter, protective vinyl carrying pouch

- 1 Memraflex grille screen
- 2 High-density Acoustifoam™ windscreen
- 3 Response-extending Helmholtz resonator
- 4 Barometric equalization port in Acoustalloy® diaphragm
- 5 Preadjusted main damping
- 6 Front butyl rubber mount
- 7 Nonmetallic shock mount support rings
- 8 High-flux magnetic structure
- 9 Isolated rear cavity, nonmetallic
- 10 Steel transducer housing
- 11 Aluminum front housing
- 12 Rear butyl rubber mount
- 13 Nonmetallic shock mount support rings
- 14 Rubber compression pad

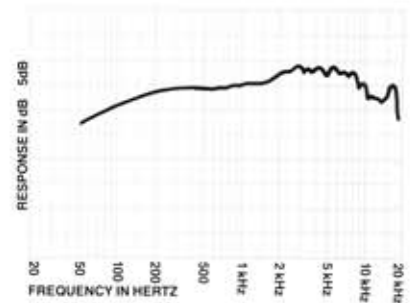

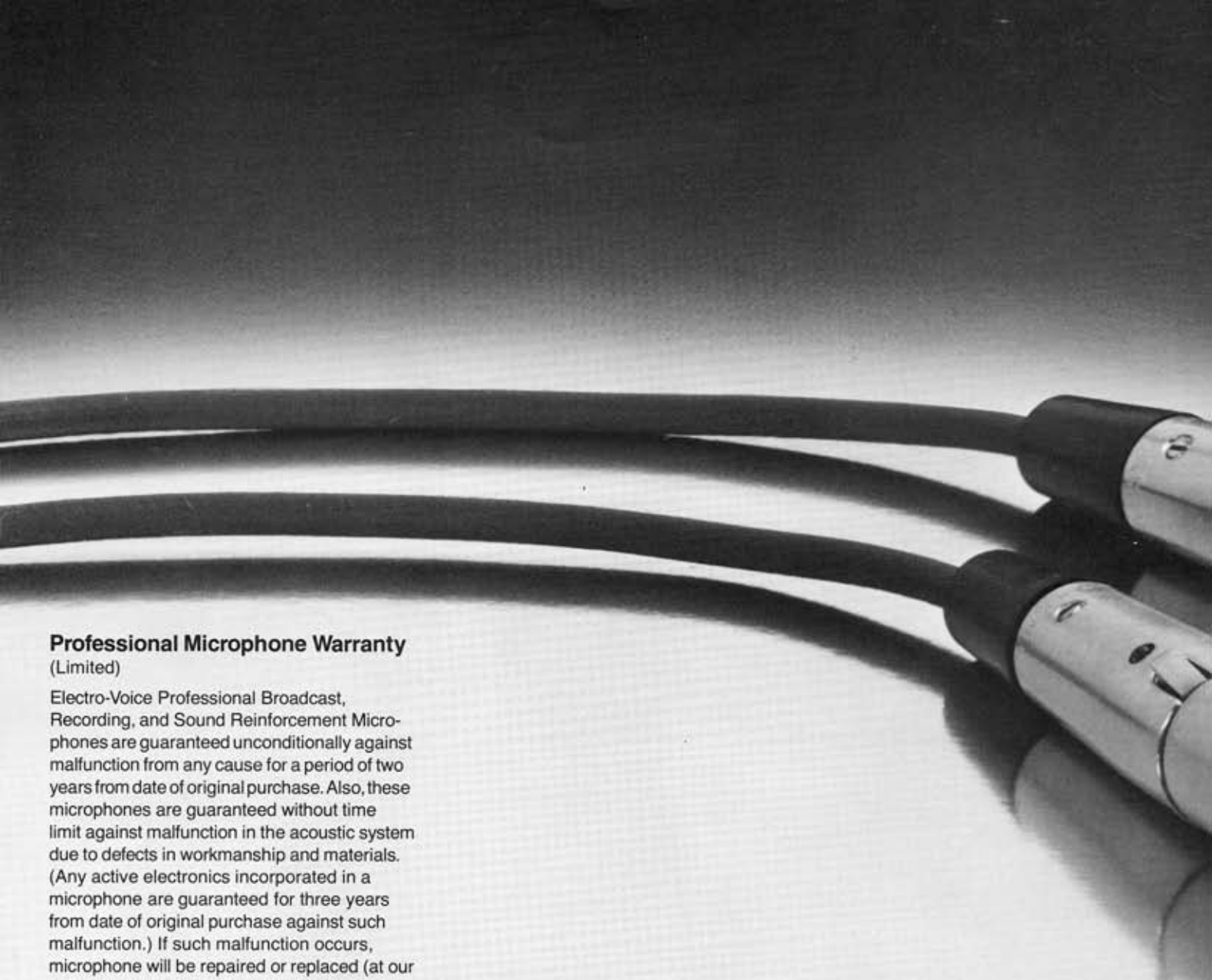

## Professional Microphone Warranty (Limited)

Electro-Voice Professional Broadcast, Recording, and Sound Reinforcement Microphones are guaranteed unconditionally against malfunction from any cause for a period of two years from date of original purchase. Also, these microphones are guaranteed without time limit against malfunction in the acoustic system due to defects in workmanship and materials. (Any active electronics incorporated in a microphone are guaranteed for three years from date of original purchase against such malfunction.) If such malfunction occurs, microphone will be repaired or replaced (at our option) without charge for materials or labor if delivered prepaid to the proper Electro-Voice service facility. Unit will be returned prepaid. Warranty does not cover finish, appearance items, cable, cable connectors, or switches. Defect guarantee does not cover malfunction due to abuse or operation at other than specified conditions. Repair by other than Electro-Voice or its authorized service agencies will void this guarantee.



**Electro-Voice®** a gulton company

600 Cecil Street, Buchanan, Michigan 49107  
7473 Avenue 304, Visalia, California 93277 •  
Electro-Voice Div., 345 Herbert Street,  
Gananoque, Ontario • Electro-Voice, S. A.,  
Romerstrasse 3, 2560 Nidau, Switzerland