

Model 671B

Dynamic Cardioid Microphone



SPECIFICATIONS

Element:

Dynamic

Frequency Response:

60–14,000 Hz

Polar Pattern:

Cardioid

Impedance Must Be Specified:

671BL — 150 ohm

671BH — Hi-Z

Output Level,

Low Impedance:

–57 dB

(0 dB = 1 mW/10 dynes/cm²)

High Impedance:

–56 dB

(0 dB = 1 V/dyne/cm²)

EIA Sensitivity Rating,

150 Ohm:

–151 dB

Hi-Z:

–152 dB

Diaphragm:

Acoustalloy®

Switch:

On-Off (lockable)

Case:

Zinc die cast

Finish:

Non reflecting gray

Accessory Included:

358 stand adapter

Optional Accessories:

351 windscreen

456 carrying case

Dimensions:

157.2 mm (6.19 in.) long

(excluding cable connector),

50 mm (1.97 in.) largest diameter

Weight:

226.8 g (8 oz)- excluding cable

Cable,

671BL:

4.6 m (15 ft), two-conductor, shielded, vinyl jacketed, with Switchcraft A3F connector

671BH:

4.6 m (15 ft), single conductor, shielded, vinyl jacketed, with Switchcraft A3F connector at the microphone end.

DESCRIPTION & APPLICATIONS

The new Electro-Voice Model 671B features high output level while providing a smooth frequency response and excellent gain-before-feedback characteristics. The Model 671B is a Single-D cardioid microphone which emphasizes low frequencies when used "close up." Perfect for the exacting needs of high quality sound reinforcement, public address, and other applications, the 671B is ruggedly designed and attractively styled. The 671B uses the broadcast standard three-pin type connector.

A new head design provides exceptionally wide, linear response for high gain-before-feedback in sound reinforcement applications. The head subassembly is user replaceable. As part of this assembly, an extremely effective shock absorber isolates the transducer assembly from mechanical noises. An internal Acoustifoam™ filter allows close talking without excessive "P-popping" and prevents dirt and magnetic particles from accumulating on the diaphragm.

The microphone is equipped with a lock to keep the switch in the "on" position if this is desired.

Utilizing The Locking Feature:

To lock the switch in the "on" position, first turn switch on. Next, using a sharp object such as a nail file or a small screwdriver, slide lock to a position behind the switch actuator (See Fig. 2).

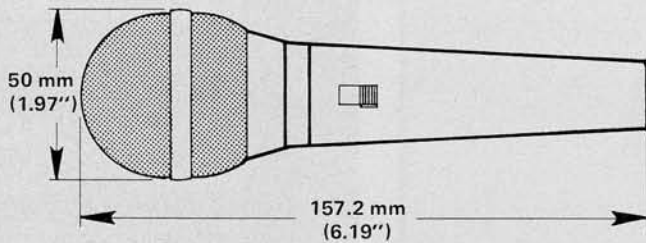

FIGURE 1 – Dimensions

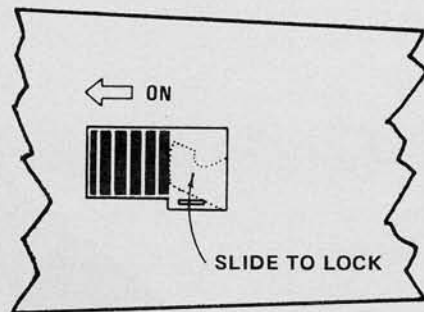

FIGURE 2 – Locking Feature

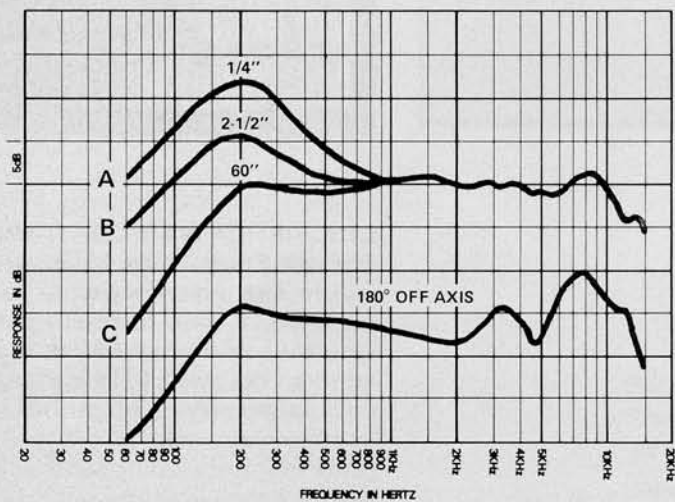

FIGURE 3 – Frequency Response

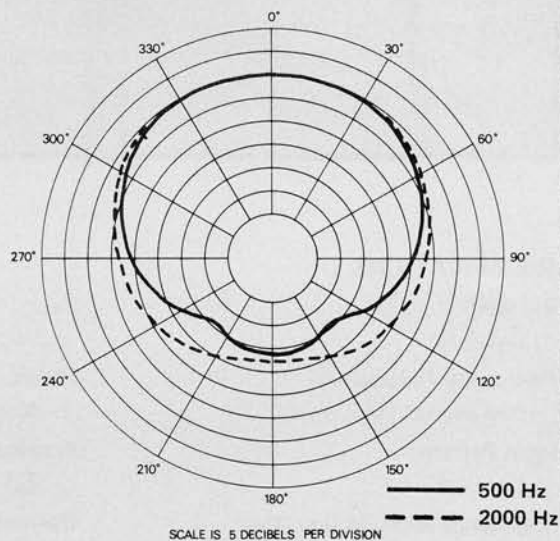

FIGURE 4 – Polar Response

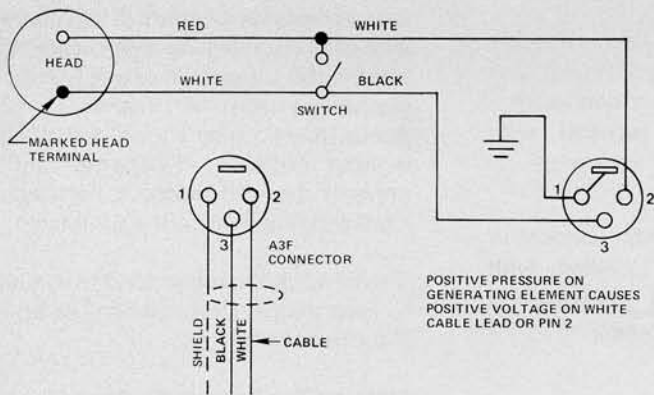

FIGURE 5 – Wiring Diagram, Lo-Z

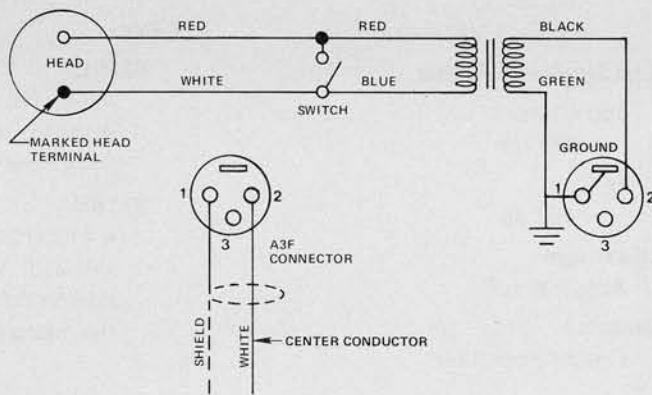

FIGURE 6 – Wiring Diagram, Hi-Z

Using The Variable Low-Frequency Response:

The 671B low-frequency response varies with the distance from the sound to the microphone as shown in the response curve (Fig. 3). Maximum bass response is produced in close-up use with the microphone 1/4" from the sound source (Fig. 3/A). Minimum bass response is experienced at distances greater than 24" (Fig. 3/C).

Useful special effects can be created by an imaginative application of the variable low-frequency response:

1. By working closer to the microphone, the human voice will sound more robust, although intelligibility may be adversely affected.
2. Feedback in a public address system is sustained by reflection of sound into the microphone. For all microphones, as the artist moves closer, the level of his voice (at the microphone) increases and the microphone's signal to the amplifier is increased. For a constant volume of sound from the system, the amplifier gain setting must be proportionately reduced. This results in a reduction of the system's sensitivity to reflected sound, hence a reduction of the tendency to feedback.

The variable low-frequency response provides a further feedback reducing advantage in close talking applications. At 1/4" low-frequency response is greatly enhanced, while response to distant sound (as from sound system loudspeakers) is unaffected. The result is a reduced tendency to feedback, over and above that provided by the cardioid directional characteristic alone.

In short, system sensitivity reduction because of close working, added to the advantage resulting from the bass boosting low-frequency characteristic of the 671B, makes this instrument an exceptionally effective tool for stage and nightclub use.

3. For musical pickup, the variable bass response can be utilized to achieve "clean" bass pickup at distances of 24" or more. By moving the 671B to a few inches from the instrument, bass will be increased.

ARCHITECTS' AND ENGINEERS' SPECIFICATIONS

The microphone shall be a cardioid dynamic type. Frequency response shall be 60-14,000 Hz, specially shaped above 1,000 Hz to maintain presence for vocal and musical pickups, and below 1,000 Hz shall vary inversely with distance. Response at the front of the microphone at 1,000 Hz shall be nominally 20 dB greater than response at rear.

The microphone shall be specified either 150 ohm balanced or Hi-Z unbalanced. Output level for high impedance shall be -56 dB (0 dB equalling 1 V/dyne/cm²). Output level for low impedance shall be -57 dB (0 dB equals 1 mW/10 dynes/cm²). Microphone shall have an Acoustalloy® diaphragm. An on-off switch shall be provided and so connected that the transducer is "shorted" when switch is in off position. A 4.6 m (15 ft), two-conductor, shielded, vinyl jacketed cable with Switchcraft A3F connector installed at the microphone end shall be provided with Lo-Z model and similar but single conductor cable provided with the Hi-Z model.

The case shall be die cast zinc. Dimensions shall be 157.2 mm (6.19") long, 50 mm (1.97") diameter. Net weight (less cable) shall be 226.8 g (8 oz.) Finish shall be satin chrome. A Model 358 stand adapter shall be furnished.

The Electro-Voice Model 671BL or 671BH is specified.

WARRANTY (Limited) —

Electro-Voice General Purpose Microphones are guaranteed without time limit against malfunction in the acoustic system due to defects in workmanship and materials. (Any active electronics incorporated in a microphone is guaranteed for three years from date of original purchase against such malfunction.) If such malfunction occurs, microphone will be repaired or replaced (at our option) without charge for materials or labor if delivered prepaid to the proper Electro-Voice service facility. Unit will be returned prepaid. Warranty does not cover finish, appearance items, cables, cable connectors, or switches and does not cover malfunction due to abuse or operation at other than specified conditions. Repair by other than Electro-Voice or its authorized service agencies will void this guarantee.

For repair information and service locations, please write: Service Department, Electro-Voice, Inc., 600 Cecil St. Buchanan, Michigan 49107 (Phone 616/695-6831) or Electro-Voice, West, 8234 Doe Avenue, Visalia, CA 93277 (Phone 290/625-1330,-1).

Electro-Voice also maintains complete facilities for non-warranty service of E-V products.

Specifications subject to change without notice.