

# Model 671A

## Single-D Cardioid Microphone

### SPECIFICATIONS

- Element:**  
Dynamic
- Frequency Response:**  
60-14,000 Hz
- Polar Pattern:**  
Cardioid
- Impedance:**  
150 ohm/Hi-Z, Selectable
- Impedance Change:**  
Rear of connector insert
- Output Level,**  
**Low Impedance:**  
-57 dB  
(0 dB = 1 mW/10 dyne/cm<sup>2</sup>)
- High Impedance:**  
-56 dB  
(0 dB = 1 v/dyne/cm<sup>2</sup>)
- EIA Sensitivity Rating,**  
**150 Ohm:**  
-151 dB
- Hi-Z:**  
-152 dB
- Diaphragm:**  
Acoustalloy®
- Switch:**  
On-Off (lockable)
- Case:**  
Zinc die cast
- Finish:**  
Satin chrome
- Accessory Included:**  
358 stand adapter
- Optional Accessory:**  
351 windscreen  
456 carrying case

- Dimensions:**  
157.2 mm (6.19") long  
(excluding cable connector),  
50 mm (1.97") largest diameter

- Weight:**  
226.8 g (8 oz)- excluding cable
- Cable,**  
**671A:**  
4.6 m (15 foot), two-conductor,  
shielded, vinyl jacketed, with  
Switchcraft A3F connector
- 671AP:**  
4.6 m (15 foot), two-conductor,  
shielded, vinyl jacketed, with  
Switchcraft A3F connector at  
the microphone end and ¼" phone  
plug at equipment end

### DESCRIPTION & APPLICATIONS

The new Electro-Voice Model 671A features high output level while providing a smooth frequency response and excellent gain-before-feedback characteristics. The Model 671A is a Single-D cardioid microphone which emphasizes low frequencies when used "close up." Perfect for the exacting needs of high quality sound reinforcement, public address, and other applications, the 671A is ruggedly designed and attractively styled.

The 671A uses the broadcast standard three-pin type connector. In addition the 671AP has a ¼" phone plug at the equipment end of the cable. The 671AP can be operated Hi-Z or unbalanced Lo-Z. (See instructions for changing impedance)

A new head design and an exclusive Volumetric-hologram designed diaphragm provide exceptionally wide, linear response at all angles of incidence for high gain-before-feedback in sound reinforcement applications, and virtual elimination of off-axis coloration. The head subassembly is user replaceable. As part of this assembly, a newly designed extremely effective shock absorber isolates the transducer assembly from mechanical noises. An internal Acoustifoam™ filter allows close talking without excessive "P-popping" and prevents dirt and magnetic particles from accumulating on the diaphragm.

The microphone is equipped with a lock to keep the switch in the "on" position if this is desired.

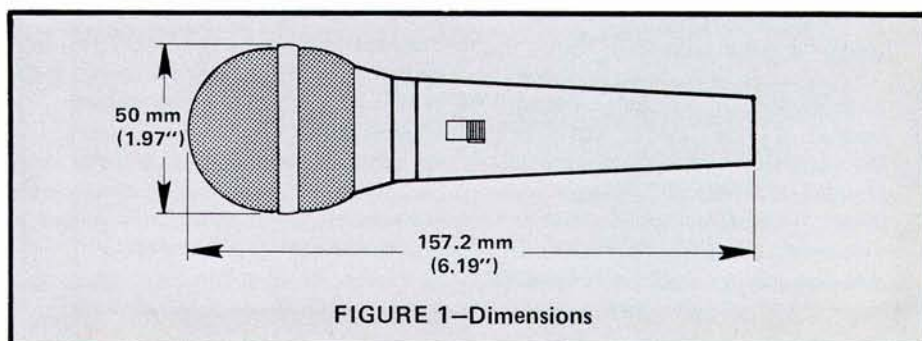

FIGURE 1—Dimensions

### Utilizing The Locking Feature:

To lock the switch in the "on" position, first turn switch on. Next, using a sharp object such as a nail file or a small screwdriver, slide lock to a position behind the switch actuator (See Fig. 2).

### Using The Variable Low-Frequency Response:

The 671A's low-frequency response varies with the distance from the sound to the microphone as shown in the response curve (Fig. 3). Maximum bass response is produced in close-up use with the microphone ¼" from the sound source (Fig. 3/A). Minimum bass response is experienced at distances greater than 24" (Fig. 3/C).

Useful special effects can be created by an imaginative application of the variable low-frequency response:

1. By working closer to the microphone, the human voice will sound more robust, although intelligibility may be adversely affected.
2. Feedback in a public address system is sustained by reflection of sound into the microphone. For all microphones, as the artist moves closer, the level of his voice (at the microphone) increases and the microphone's signal to the amplifier is increased. For a constant volume of sound from the system, the amplifier gain setting must be proportionately reduced. This results in a reduction of the system's sensitivity to reflected sound, hence a reduction of the tendency to feedback.

The variable low-frequency response of the 671A provides a further feedback reducing advantage in close talking applications. At ¼", low-frequency response is greatly enhanced, while response to distant sound (as from sound system loudspeakers) is unaffected. The result is a reduced tendency to feedback, over and above that provided by the cardioid directional characteristic alone.

In short, system sensitivity reduction because of close working, added to the advantage resulting from the bass boosting low-frequency characteristic of the 671A, makes this instrument an exceptionally effective tool for stage and nightclub use.

3. For the variable bass response can be utilized to achieve "clean" bass pickup at distances of 24" or more. By moving the 671A to a few inches from the instrument, bass will be increased.

**Caution notes:** With the sound source (lips) closer than 2", bass response is increased dramatically (as shown in Fig. 3/A/B). If too much signal is generated at the microphone, overloading in the amplifier input circuits may occur, causing severe distortion.

### Impedance Change Instructions:

Impedance may be changed from Hi- to Lo-Z, or vice-versa, by changing one pin-connector at the rear of the microphone. Turn the setscrew in the connector-insert counter clockwise (it is a reverse-threaded screw and will not come out, but rather disappear into the insert). Pull the insert straight out from the end of the microphone exposing the wires connected to it. (See Fig. 6) For high impedance, the black wire should be connected to Pin 2 of the insert. For low impedance, the red wire should be connected to Pin 2. (A sleeve on the connector slides over the pin to insulate and assure a tight connection.)

Unbalanced Lo-Z and Hi-Z operation requires that the black wire at the equipment end of the cable be connected together with the ground shield to the sleeve (or ground connection) of the ¼" phone plug. The white wire is connected to the tip (or positive). (See Fig. 7) This is the way the plug is connected on the 671AP model. Impedance may be changed to unbalanced Lo-Z as described above. Figure 7 also shows the connection for a balanced Lo-Z operation using standard 3-pin connector such as the Switchcraft A3M.

### ARCHITECTS' AND ENGINEERS' SPECIFICATIONS

The microphone shall be a cardioid dynamic type. Frequency response shall be 60–14,000 Hz, specially shaped above 1,000 Hz to maintain presence for vocal and musical pickups, and below 1,000 Hz shall vary inversely with distance. Response at the front of the microphone at 1,000 Hz shall be nominally 20 dB greater than response at rear.

The microphone shall be a switchable impedance type (high impedance or 150 ohm balanced or unbalanced low impedance). Output level for high impedance shall be -56 dB (0 dB equalling 1 v/dyne/cm<sup>2</sup>). Output level for low impedance shall be -57 dB (0 dB equals 1 mW/10 dynes/cm<sup>2</sup>). Microphone shall have an Acoustalloy<sup>®</sup> diaphragm. An on-off switch shall be provided and so connected that the transducer is "shorted" when switch is in off position. A 4.6 m (15 ft), two-conductor, shielded, vinyl jacketed cable with Switchcraft A3F connector installed at the microphone end shall be provided.

The case shall be die cast zinc. Dimensions shall be 157.2 mm (6.19") long, 50 mm (1.97") diameter. Net weight (less cable) shall be 226.8 g (8 oz). Finish shall be satin chrome. A Model 358 stand adapter shall be furnished.

The Electro-Voice Model 671A is specified.

### WARRANTY (Limited) –

Electro-Voice General Purpose Microphones are guaranteed without time limit against malfunction in the acoustic system due to defects in workmanship and materials. (Any active electronics incorporated in a microphone is guaranteed for three years from date of original purchase against such malfunction.) If such malfunction occurs, microphone will be repaired or replaced (at our option) without charge for materials or labor if delivered prepaid to the proper Electro-Voice service facility. Unit will be returned prepaid. Warranty does not cover finish, appearance items, cables, cable connectors, or switches and does not cover malfunction due to abuse or operation at other than specified conditions. Repair by other than Electro-Voice or its authorized service agencies will void this guarantee.

For repair information and service locations, please write: Service Department, Electro-Voice, Inc., 600 Cecil Street, Buchanan, Michigan 49107 (Phone 616/695-6831) or 7473 Avenue 304, Visalia, CA 93277 (209/625-1330,-1).

Electro-Voice also maintains complete facilities for non-warranty service of E-V products.

Specifications subject to change without notice.



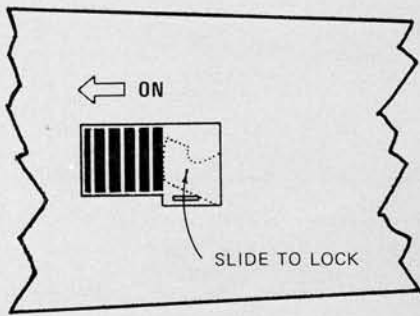

FIGURE 2—Locking Feature

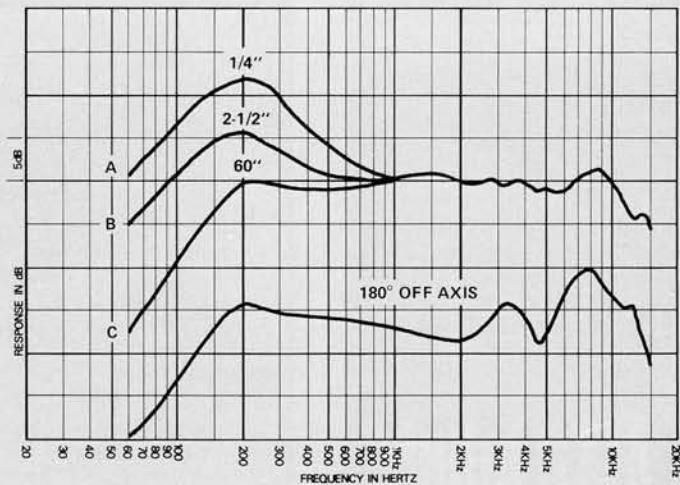

FIGURE 3—Frequency Response

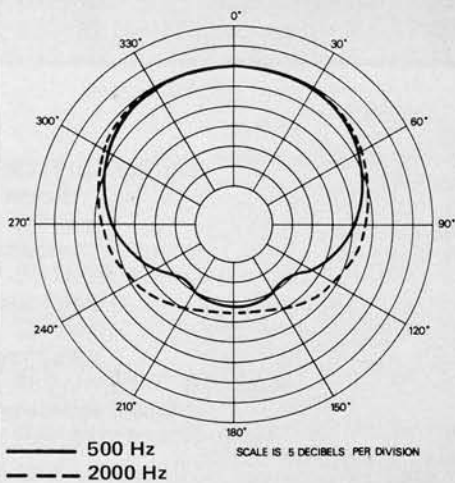

FIGURE 4 – Polar Response

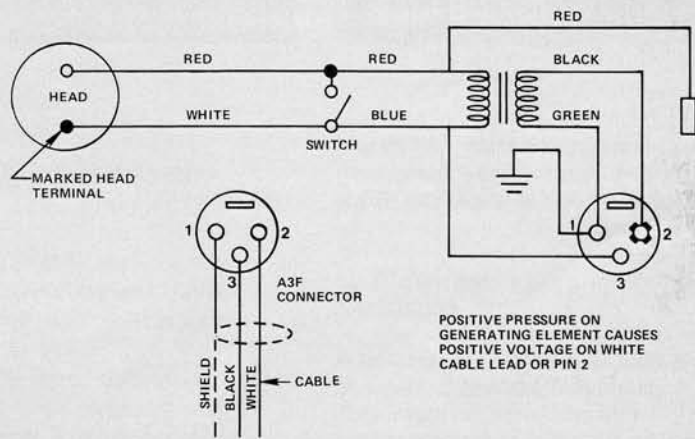

FIGURE 5—Wiring Diagram

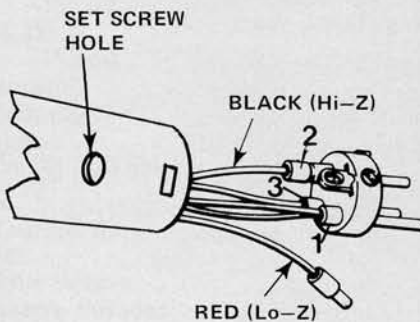

FIGURE 6—Changing Impedance

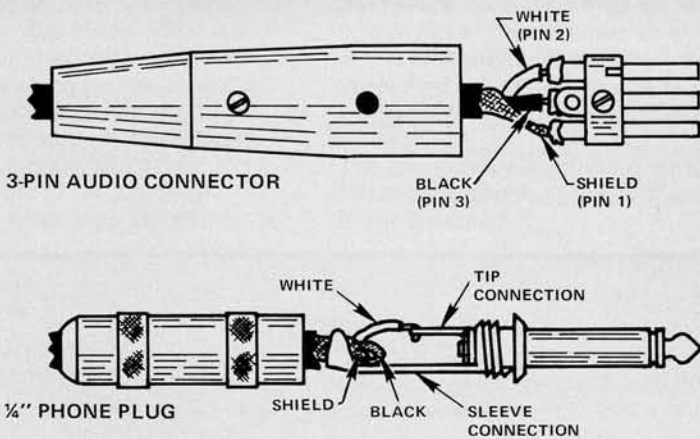

FIGURE 7 – 3-Pin Connector & 1/4" Phone Plug Wiring Connections