

Electro-Voice®

ELECTRO-VOICE, INC.
BUCHANAN, MICHIGAN



Specifications

Model 647 Microphone



Fig. 1 — Model 647 Microphone

The Electro-Voice Model 647 Lavalier Microphone is a dynamic omnidirectional type providing smooth, wide range response and high output. This slim, miniaturized microphone can be hung on a neck cord close to the chest — leaving hands of the announcer or performer free for demonstrations — or it can be held in the hand, used on a desk stand, or suspended from a boom. It is excellent for use wherever microphone concealment, individual mobility, or free movement of the hands is desired. No closely associated auxiliary equipment is required.

The microphone is equipped with a pop-proof wire mesh grille which minimizes wind and breath blasts. Supplied complete with combination neck cord and tie clip for microphone, belt clip for cable and 18 ft. cable.

The model 647 features the exclusive Electro-Voice Acoustalloy diaphragm. This nonmetallic diaphragm permits smooth response over a wide frequency range and withstands high humidity, temperature extremes, corrosive effects of salt air and severe mechanical shocks. It is practically indestructible with normal use.

SPECIFICATIONS

Type: Dynamic

Frequency Response: Smooth, peak-free, 60 to 10,000 cps, with slightly rising characteristic specifically calculated to assure crisp, clear pickup when Model 647 is used on the chest as a lavalier, in the hand or on a desk.

Impedance: 150 ohms and high-impedance selected on internal terminal board. See Fig. 6 and cable instructions.

Output Level:

150 ohms: -57 db*; RETMA Sensitivity Rating -151 db

High-impedance: -57 db**; RETMA Sensitivity Rating -153 db

*0 db equals 1 mw/10 dynes/cm²

**0 db equals 1 volt/dyne/cm²

Polar Pattern: Omnidirectional, becoming directional at extremely high frequencies. See Figure 3

Diaphragm: Electro-Voice Acoustalloy

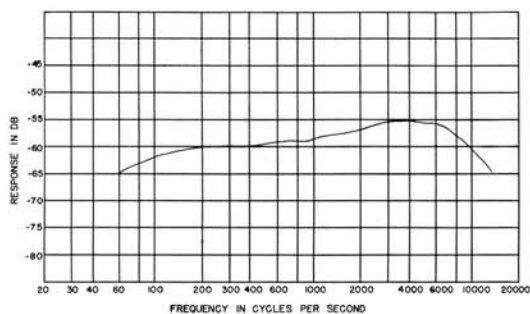
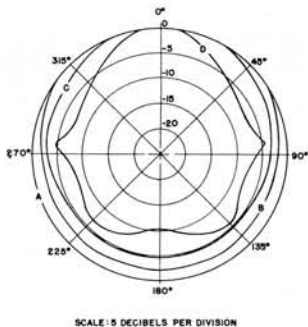

Fig. 2 — Response

Electro-Voice Specifications / Model 647 Microphone



SCALE: 5 DECIBELS PER DIVISION
 A — 500 cps C — 5,000 cps
 B — 1,500 cps D — 10,000 cps

Fig. 3 — Polar Pattern

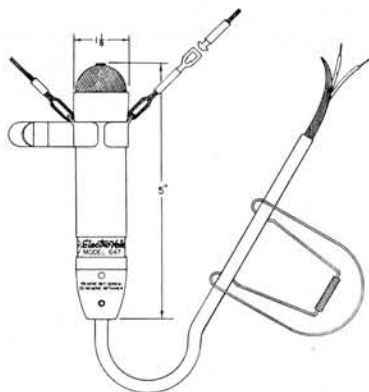

Fig. 4 — Dimensions

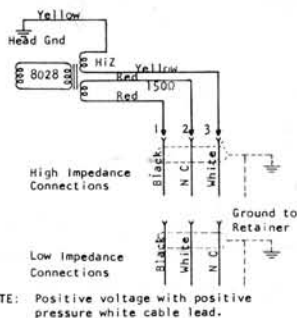

Fig. 5 — Wiring Diagram

Magnetic Circuit: Employs Alnico V and Armco magnetic iron in a nonwelded, precision-ground, magnetic structure.

Case: Lathe turned, high tensile strength aluminum

Finish: Black alumilite with satin chromium trim and clip

Cable: Standard broadcast, two-conductor, shielded, synthetic-jacketed, 18 ft. long

Cable Connector: Lug type, detachable. See Figure 6

Dimensions: Diameter: 1 1/8 in., Length: 5 in. See Figure 4

Net Weight: 6 oz, less Cable

Standard Accessories: Hex Key Wrench, Belt strain relief clip, Spanner wrench and Neck cord sub assembly

Optional Accessories: Model 300 Stand Adapter, Model 366 Suspension Shock Mount, Model 416 and 420 Desk Stand.

Warranty: The Electro-Voice Model 647 Microphone is guaranteed against defects in workmanship and material.

CABLE INSTRUCTIONS

To remove cable from microphone:

1. Loosen set screw (B) in strain relief nut (A).
2. Hold cable to prevent twisting while unscrewing strain relief nut (A), slide strain relief nut down cable.
3. Remove cable by pulling female connectors from terminal pins in microphone.

To attach cable to microphone:

Place female connectors on proper terminal pins, start strain relief nut (A) and hold cable to prevent twisting while screwing up tight. Push slack in cable into microphone until last clamp band is flush with strain relief nut (A). Tighten set screw.

Low-Z Hookup
 1 — Black
 2 — White
 3 — NC



High-Z Hookup
 1 — Black
 2 — NC
 3 — White

Bottom view Model 647 with strain relief nut removed

NOTE: Shield clamped under cable clamp (D) for both High-Z and Low-Z. For correct operation strain relief nut (A) and cable assembly must be in place as shown in Fig. 6.

Architects' and Engineers' Specifications

The microphone shall be an Electro-Voice Model 647 or equivalent. The microphone shall be an omnidirectional, dynamic type with wide-range, uniform response from 60 to 10,000 cps. The diaphragm shall be nonmetallic Acoustalloy and shall have a magnetic shield to prevent dust and iron particles from reaching the diaphragm. The available impedances shall be Hi-Z and 150 ohms. The line shall be balanced to ground on 150 ohms. Output shall be phased with regard to polarity.

The output level for 150 ohms shall be -57 db with 0 db equalling 1 mw/10 dynes/cm²; EIA Sensitivity Rating -151 db. Hi-Z impedance output shall be -57 db with 0 db equalling 1 volt/dyne/cm²; EIA Sensitivity Rating -153 db. The magnetic circuit shall be a nonwelded circuit and employ Alnico V and Armco magnetic iron. The case shall be made of high tensile aluminum. The microphone shall have a diameter of 1 1/8 in., and a weight without cable of 6 oz. Finish shall be Black Alumilite with satin chromium trim and clip. An 18-ft. two-conductor, shielded, black, synthetic-jacketed, broadcast type cable shall be provided. The microphone shall have a lug-type, detachable connector. Impedance shall be selected on internal terminal board. Electro-Voice Model 647 is specified.

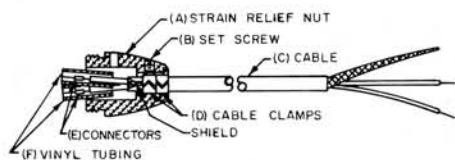

Fig. 6 — Cable Connector



ELECTRO-VOICE, INC. / BUCHANAN, MICHIGAN